

U.S. Patents: #4,785,519 #5,031,294 #5,680,686

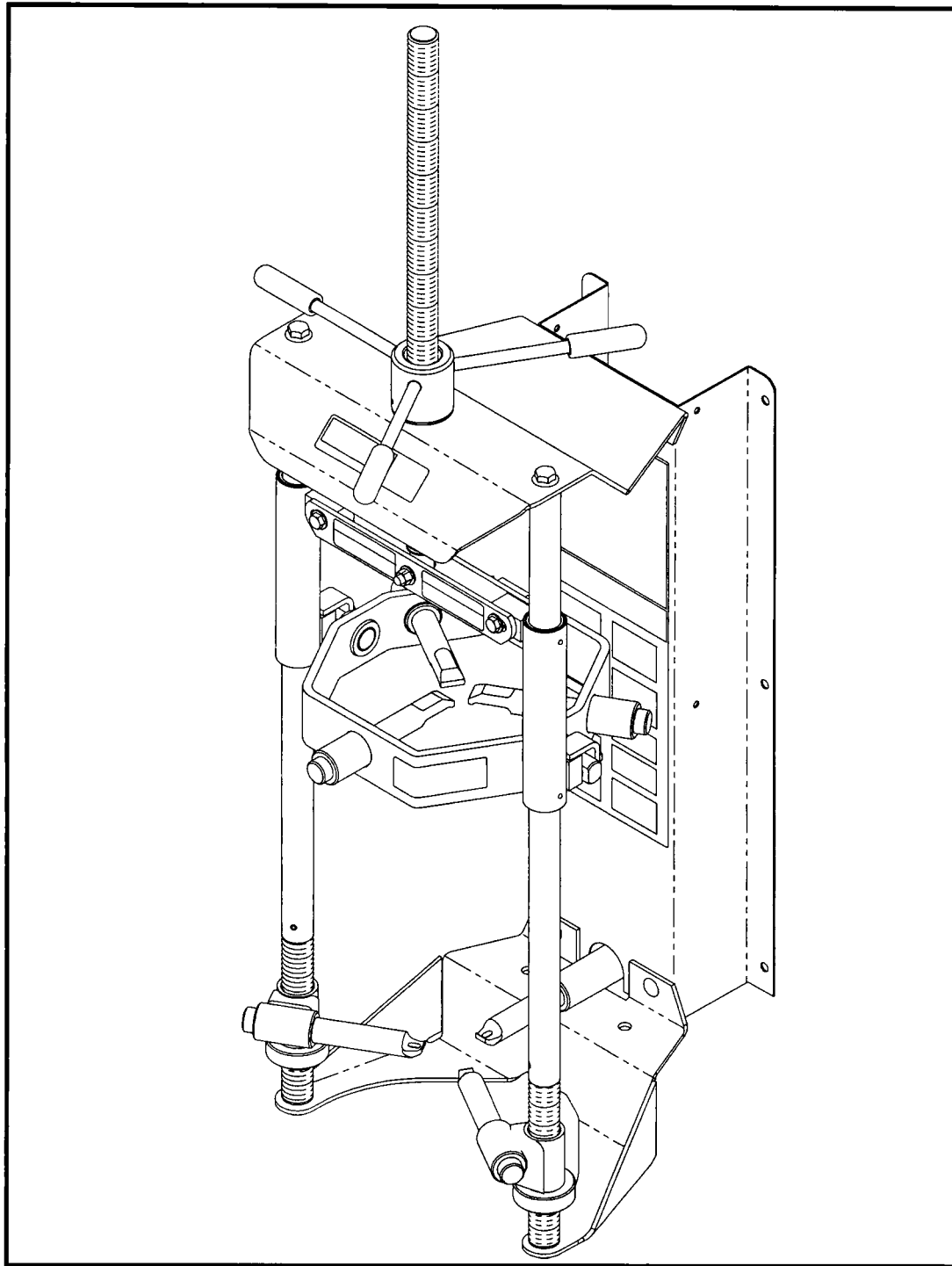

⚠ CAUTION

- ◆ Before using this product, read and fully understand the operating instructions and all decals on the product. This is necessary to prevent injury to the operator and damage to the product.
- ◆ Use this tool on strut springs only. Do not attempt to compress any other type of spring, or use this tool for any other purpose.
- ◆ Do not use this tool if it is visibly worn, distorted or damaged.
- ◆ Always check condition of rubber hook pads on all six hooks before using this tool. Replace if damaged or missing.
- ◆ Always wear appropriate eye protection.
- ◆ Inspect the spring of the strut assembly for any damage or corrosion. Spring breakage during compression could cause injury.

⚠ WARNING

- ◆ Failure to properly position the strut assembly in tool could result in serious injury from sudden release of the strut assembly parts.

Step 1. POSITIONING THE STRUT ASSEMBLY

- A) Adjust lower right hook to a position just below the lower center hook. Adjust lower left hook to a position just above the lower center hook.

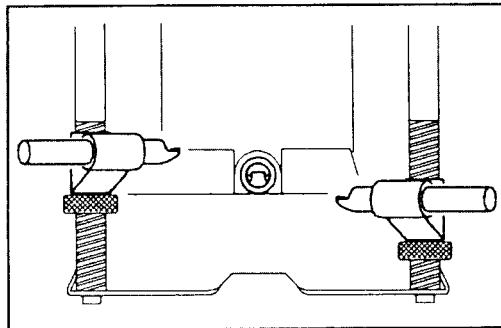

- B) Place strut assembly on the lower center hook using the lowest possible coil of spring.

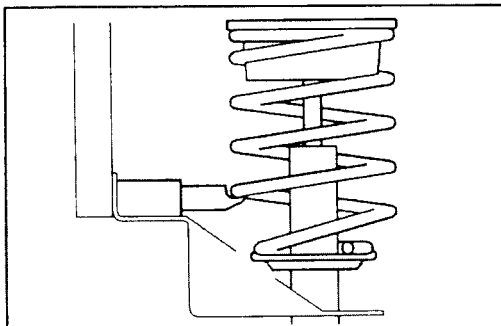

C) Engage lower left and right hooks with spring. Center the spring within lower hooks. The three lower hooks should be equally extended.

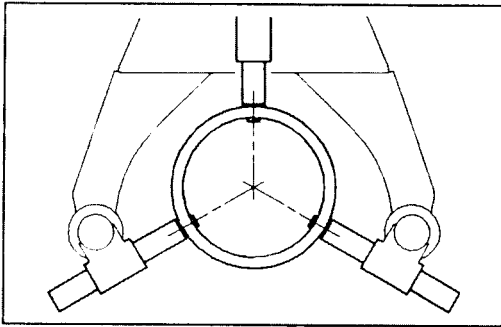

CORRECT

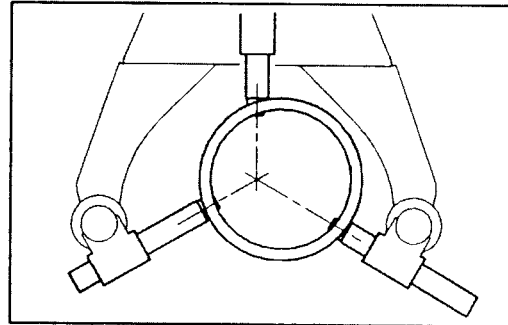

INCORRECT

D) Align strut assembly by adjusting the lower left and right hooks. When properly aligned, the **spring** of strut assembly will be parallel to the posts of the tool when viewed from both the front and side.

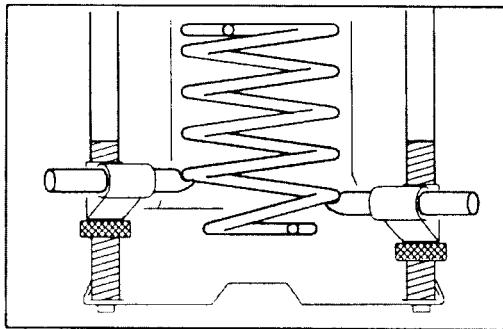

FRONT
CORRECT

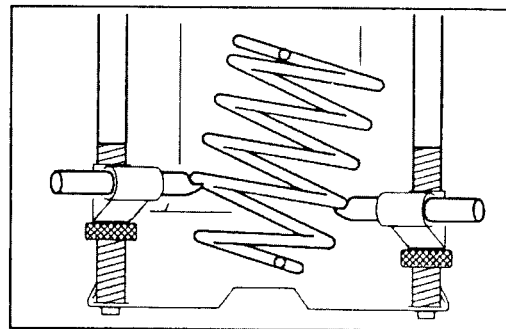

FRONT
INCORRECT

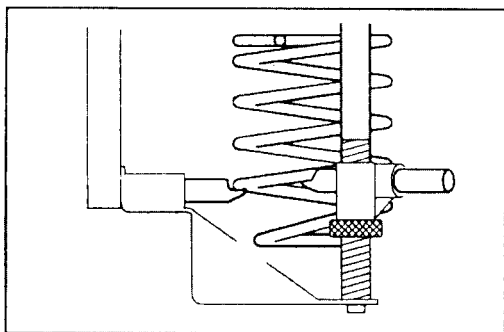

SIDE
CORRECT

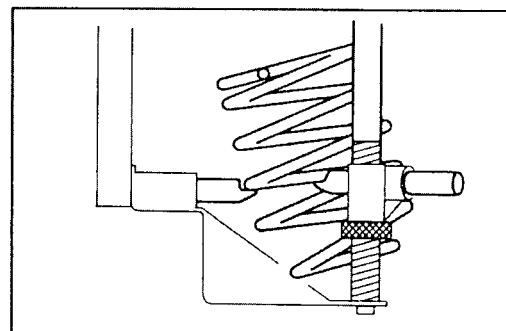

SIDE
INCORRECT

E) Identify the strut assembly type you are servicing.

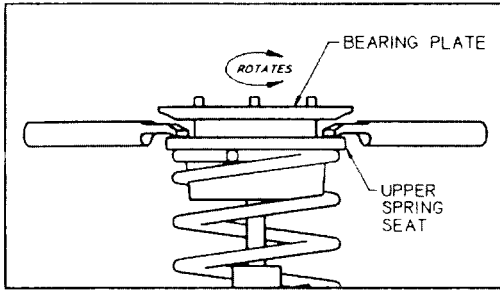

Type 1

This type of strut has a bearing plate (which rotates) and upper spring seat. Place upper hooks on the upper spring seat. **Do not place hooks on bearing plate.**

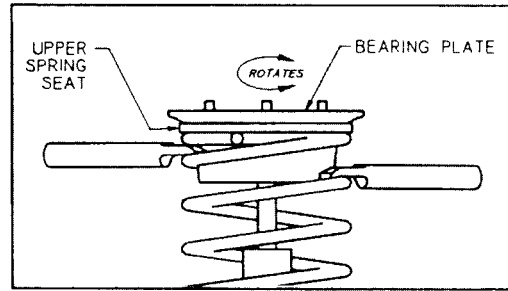

Type 2

This type of strut has a bearing plate (which rotates) and upper spring seat without space between them. Place upper hooks on the highest coil of the spring. **Do not place hooks on bearing plate.**

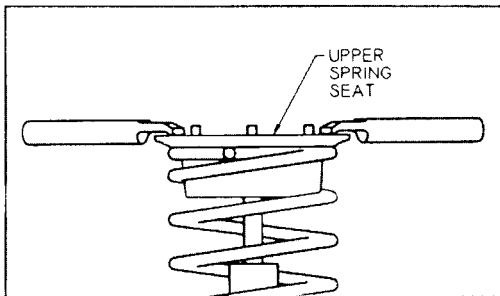

Type 3

This type of strut has only an upper spring seat. Place upper hooks on upper spring seat.

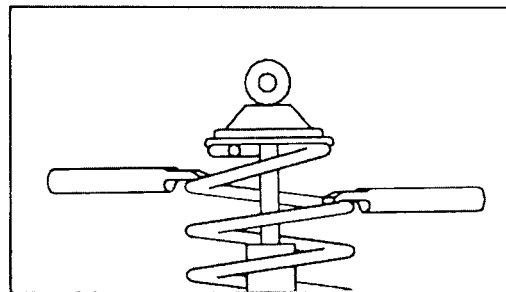

Type 4

This is a coil over shock. Place upper hooks on the highest coil of the spring.

F) Engage all three upper hooks as shown above for the type of strut assembly you are servicing. The three upper hooks should be equally extended.

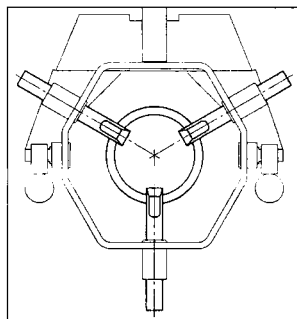

CORRECT

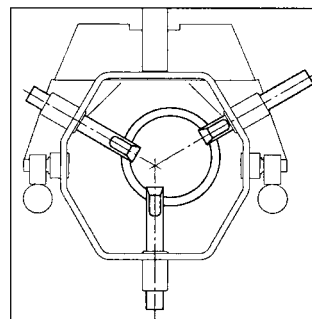

INCORRECT

Step 2. **DISASSEMBLY**

⚠ CAUTION

- ◆ If the strut assembly is difficult to compress or the spring bows or tilts, release tension and reposition the strut assembly.
- ◆ Keep fingers and hands clear of the upper hook area at all times.

- A) With the strut assembly properly positioned, turn handles to compress spring until the bottom coil of spring is just free of the lower spring seat. **DO NOT OVER COMPRESS THE SPRING!**
- B) Secure strut to spring with the clamp to prevent strut from dropping out unexpectedly.

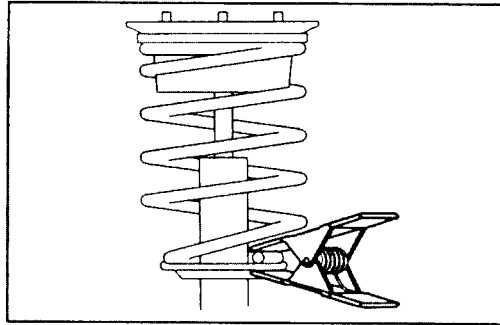

- C) Mark upper strut parts to aid in reassembly.

⚠ WARNING
<ul style="list-style-type: none">◆ Use extreme care when working with a compressed spring.◆ Never remove the piston rod nut when there is any spring pressure on the lower spring seat.

- D) Remove the piston rod nut.
- E) Remove the clamp while holding strut. Carefully remove strut and related parts.
- F) Service or replace strut as required. It is not necessary to release spring from tool when servicing strut only.

NOTE:

When replacing top spring seat or spring, make note of the position of the spring seat and spring before releasing spring from tool. Replace new strut parts in tool in the same position as the old.

Step 3. REASSEMBLY

- 1) Position the new strut within spring. Secure strut to spring with the clamp.
- 2) Install piston rod nut. **NUT MUST BE FULLY ENGAGED ON PISTON ROD THREADS!**
- 3) Release pressure on spring. Remove the clamp. Remove strut assembly from tool.

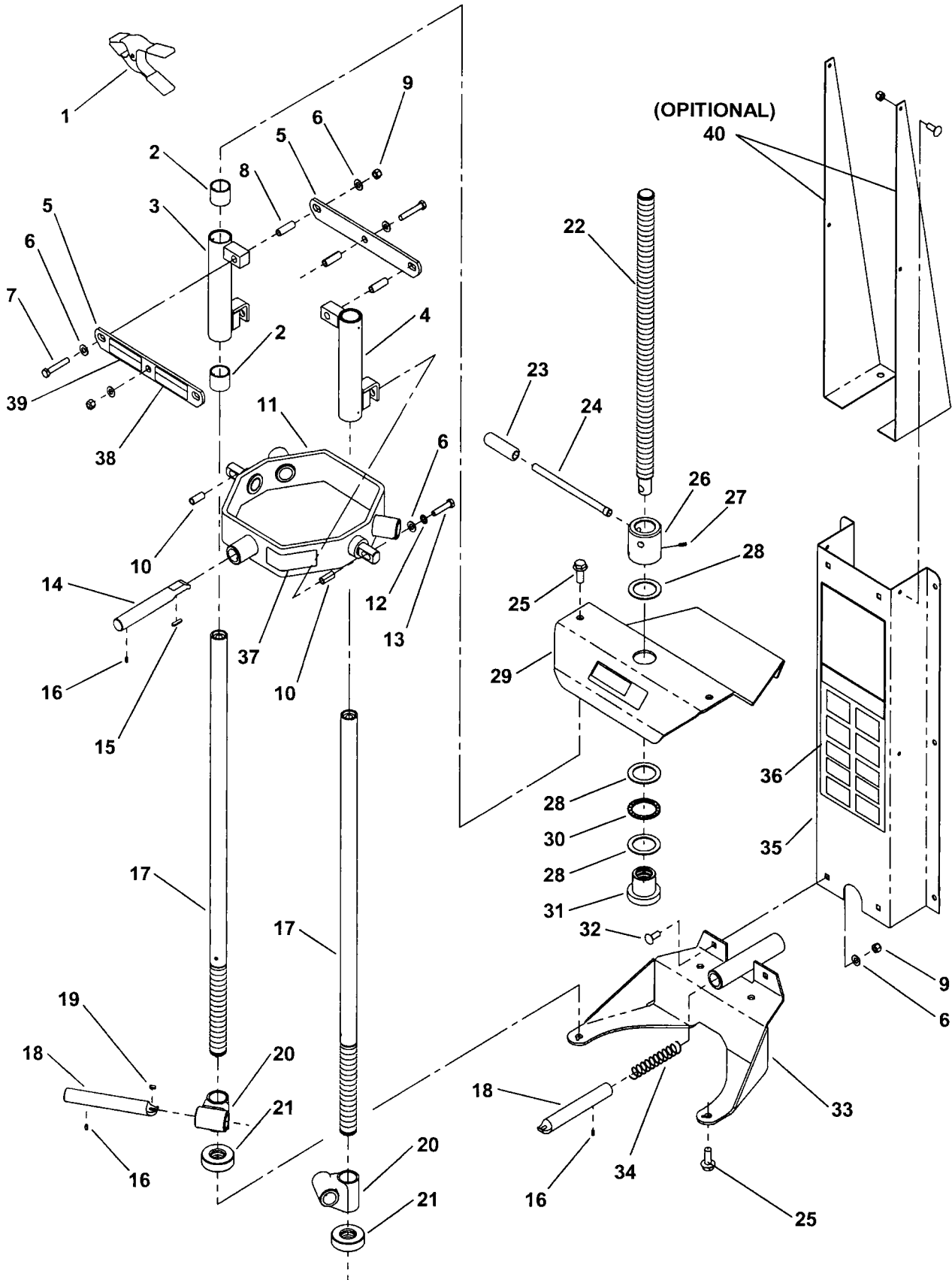

MODEL 7200 SERVICE PARTS

ITEM	PART NO	QTY	DESCRIPTION
1	53-0008	1	Spring Clamp
2	039-079	4	Nylon Bushing
3	01-0113	1	Linkage Guide - Left
4	01-0112	1	Linkage Guide - Right
5	01-0109	2	Linkage Bar <i>(With Decals)</i>
6	108-015	12	3/8 SAE Flat Washer
7	028-033	3	3/8-16 X 2-1/4 Hex Head Cap Screw
8	20-0014	3	Linkage Bar Bushing
9	055-154	7	3/8-16 Nylon Hex Lock Nut
10	20-0013	2	Pivot Bar Bushing
11	01-0208	1	Compression Ring <i>(With Decals)</i>
12	108-057	2	3/8 Internal Tooth Lock Washer
13	028-039	2	3/8-16 X 1-3/4 Hex Head Cap Screw
14	01-0115	3	Upper Hook <i>(With Pad)</i>
15	10-0012	3	Upper Hook Pad
16	061-042	6	3/16 X 3/8 Spring Pin
17	01-0085	2	Post & Adjustment Screw Shaft
18	01-0116	3	Lower Hook <i>(With Pad)</i>
19	10-0011	3	Lower Hook Pad
20	03-0092	2	Adjustable Hook Housing
21	51-0015	2	ACME Adjustment Nut
22	21-0007	1	ACME Drive Shaft
23	10-0022	3	Foam Handle Grip
24	73-0242	3	Threaded Handle Rod
25	50-0068	4	1/2-13 X 1-1/4 Hex Head Ser Flange Screw
26	21-0006	1	Handle Hub
27	54-0010	2	3/16 X 9/16 Spring Pin
28	108-137	3	Thrust Washer
29	01-0111	1	Top Plate <i>(With Decal)</i>
30	107-097	1	Thrust Bearing
31	21-0005	1	Threaded Hub
32	028-064	4	3/8-16 X 1 Carriage Bolt
33	03-0094	1	Bottom Plate
34	55-0005	1	Compression Spring
35	01-0110	1	Back Panel <i>(With Decals)</i>
36	80-0046	1	Instruction Decal
37	80-0049	2	Caution Decal
38	80-0047	1	Warning Decal
39	80-0048	1	Warning Decal
40	05-0010		Model 721 Bench Mount Kit <i>(Optional)</i>

COMMERCIAL WARRANTY

This product is warranted by BRANICK INDUSTRIES, INC. to the original user-owner against defective materials or workmanship for a period of one year from the date of delivery. During the warranty period, product found to be defective will be repaired or replaced at, BRANICK INDUSTRIES, INC.'s option, without charge. The product must be returned, with prior approval, transportation charges prepaid and with proof of original delivery date, to BRANICK INDUSTRIES, INC., 4245 Main Ave., Fargo, North Dakota 58107. The repaired or replacement product will be returned with transportation charges prepaid by Branick.

This warranty does not cover defects in the product caused by ordinary wear and tear, abuse, misuse, overloading, accident (including shipping damage), improper maintenance, alteration, or any other cause not the result of defective materials or workmanship.

REPAIR OR REPLACEMENT IS THE EXCLUSIVE REMEDY FOR DEFECTIVE PRODUCT UNDER THIS WARRANTY. THIS WARRANTY IS EXPRESSLY IN LIEU OF ALL OTHER WARRANTIES, INCLUDING ANY IMPLIED WARRANTY OF MERCHANTABILITY OR ANY IMPLIED WARRANTY OF FITNESS FOR A PARTICULAR PURPOSE OF THIS PRODUCT. BRANICK INDUSTRIES, INC. SHALL NOT BE LIABLE FOR ANY CONSEQUENTIAL OR INCIDENTAL DAMAGES.

BRANICK INDUSTRIES, INC. reserves the right to make changes in the design or construction of our products without obligation to incorporate such changes in products already sold and without notice.

Service parts, warranty, and regular repair service for products are available from Branick authorized distributors or from:

BRANICK INDUSTRIES, INC.
4245 Main Ave.
Box 1937
Fargo, North Dakota 58107
701/281-8888

Branick®
INDUSTRIES, Inc.

Printed in U.S.A.

STRUT SPRING COMPRESSOR ASSEMBLY AND SETUP INSTRUCTIONS

WALL/POST MOUNTING

Locate holes and secure to wall/post using six 3/8" fasteners (not provided).

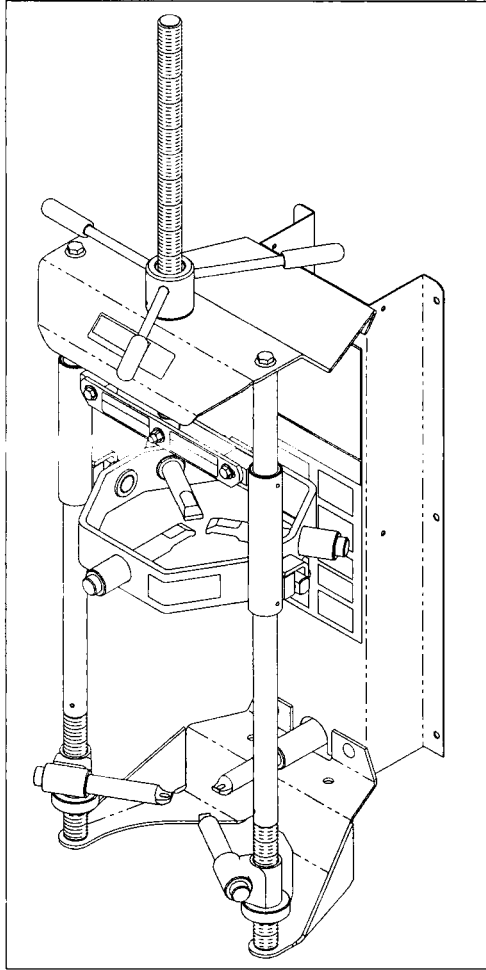

BENCH MOUNTING (Optional)

Fasten the bench mount bracket to the tool with fasteners provided. Locate holes and secure to bench using four 1/2" fasteners (not provided).

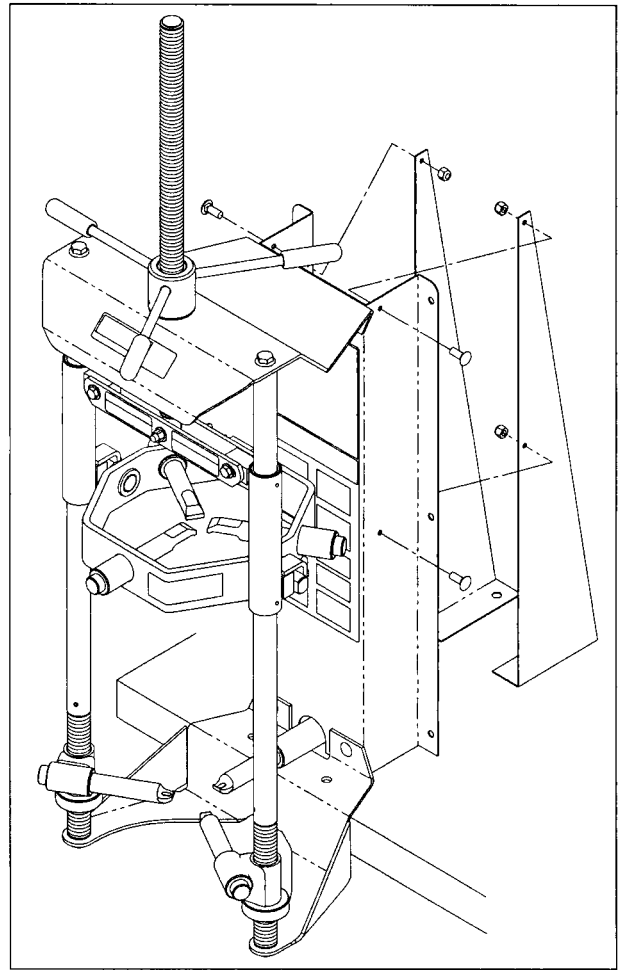

NOTE: What ever mounting method is used, the tool must be securely fastened before use.

*If the tool has any damaged or missing parts,
call Branick Industries, Inc. customer service at 1-800-437-4394*

SEE OPERATING INSTRUCTIONS FOR TOOL OPERATION