



**MODEL 465
NITROGEN INFLATION
SYSTEM**

Installation, Operation
& Repair Parts
Information



Branick Industries, Inc. • 4245 Main Avenue • Fargo, North Dakota 58103

TABLE OF CONTENTS

SAFETY INSTRUCTIONS	2
DEFINITIONS	2
SPECIFICATIONS	3
INSTALLATION INSTRUCTIONS	4
COMPONENT IDENTIFICATION	5
OPERATING INSTRUCTIONS	6
MAINTENANCE	7
REPAIR PARTS	8-9
REPAIR PARTS LIST	10-11
WARRANTY	12

SAFETY INSTRUCTIONS

- NEVER allow unauthorized personnel to operate this product.
- NEVER use this product for anything other than its intended use.
- THOROUGHLY train new employees in the proper use and care of this product.
- PROHIBIT unauthorized personnel from being in shop area while this product is in use.

DEFINITIONS

- **CAUTION:** Indicates a potentially hazardous situation, which if not avoided, may result in damage to property or minor personal injury.
- **HAZARD:** A source of potential injury to a person.
- **MAINTENANCE:** Those actions that preserve the correct and proper conditions under which the machine shall be used. This may include adjustment, replacement of wear items, lubrication and cleaning, but not modifications or repair of damage.
- **MAY:** This word is understood to be permissive.
- **MUST:** This word is understood to be mandatory.
- **OPERATION:** The correct and proper use of the machine as described in this manual.
- **SAFETY ALERT SYMBOL:** A symbol that indicates a potential personal safety hazard. It is composed of an equilateral triangle surrounding an exclamation point.
- **SHALL:** This word is understood to be mandatory.
- **SHOULD:** This word is understood to be advisory.
- **WARNING:** Indicates a potentially hazardous situation, which if not avoided, may result in death or serious personal injury.

CAUTION

- ◆ Before using this product, read and fully understand the operating instructions and all decals on the product. This is necessary to prevent injury to the operator and damage to the product.
- ◆ Do not attempt to use this product for anything other than its intended purpose.
- ◆ Use of this product should be in a suitably ventilated shop.
- ◆ Operate valves slowly to prevent damage to coalescing filter.
- ◆ Use of this product is only permitted in places free from explosion or fire hazard.
- ◆ Do not use this product if it is visibly worn, distorted or damaged.

SPECIFICATIONS

Operating Temperature	40° to 140° F (4° to 60° C)
Min/Max Compressed Air Supply	100 to 175 psi (6.9 to 12.0 bar)
Digital Inflator Accuracy	+/- 0.5% of full scale reading
Display Increments	1 psi (0.1 bar)
Dimensional data	24 x 24.5 x 54 in (61x 62 x 137 cm)
Weight:	225 lbs (102 kgs)

Specifications shown below are at an air temperature of 75° F (24° C) and a supply air pressure of 125psi (8.6 bar). These specifications are intended to be a baseline to result in the production of 95% pure Nitrogen. The output flow of Nitrogen has been pre-set to 3.2 scfm (5.1 Nm³/hr) per membrane. Changes to air temperature, supply air pressure or supply air flow will change the result of Nitrogen purity.

Model #	Supply Air Pressure		Supply Air Flow		Maximum Output N ₂ Flow		N ₂ Purity
	psi	bar	scfm	Nm ³ /hr	scfm	Nm ³ /hr	
465	125	8.6	6.3	10.1	3.2	5.1	95%

Change	Note	Result
When supply air temperature increases	Supply air flow requirement will increase	Nitrogen Purity increases
When supply air pressure increases		
When supply air flow decreases	N ₂ output flow will decrease	
When supply air temperature decreases		Nitrogen Purity decreases
When supply air pressure decreases		

INTENDED USE

The Nitrogen Inflation System is a pneumatic device designed to generate deoxygenated air for the purpose of inflating vehicle tires.

INSTALLATION INSTRUCTIONS

1. Unpack and remove unit from shipping carton and pallet.
2. Inspect the unit for any visible damage.
3. Make sure the installation location is free from explosion or fire hazard and is a suitably ventilated; otherwise, ventilate the area periodically during use of the equipment.
4. Connect an **air** supply line to your compressed air source. *Be certain there is at least 30 feet of uninsulated metallic plumbing with a minimum I.D. of 3/8" between the air compressor holding tank and the inlet port of the Nitrogen system. This distance is recommended to allow moist air to condense before reaching the Nitrogen system.*

NOTE:

- *The air supply line feeding your Nitrogen system must not have an oiler or a regulator adjusted below the minimum required pressure.. An oiler will send oil to the Nitrogen system which will prematurely plug the pre-filters.*
- *The Nitrogen generator has a filter system that captures oil, water and other contaminants. However, if your air supply system generates an excessive amount of water, etc., it may be desirable to install an air dryer.*
- *The air supply should be 125 psi (8.6 bar) minimum.*

NOTICE:

The presence of any oil in the Nitrogen Membrane will void the manufacturer's warranty.

COMPONENT IDENTIFICATION

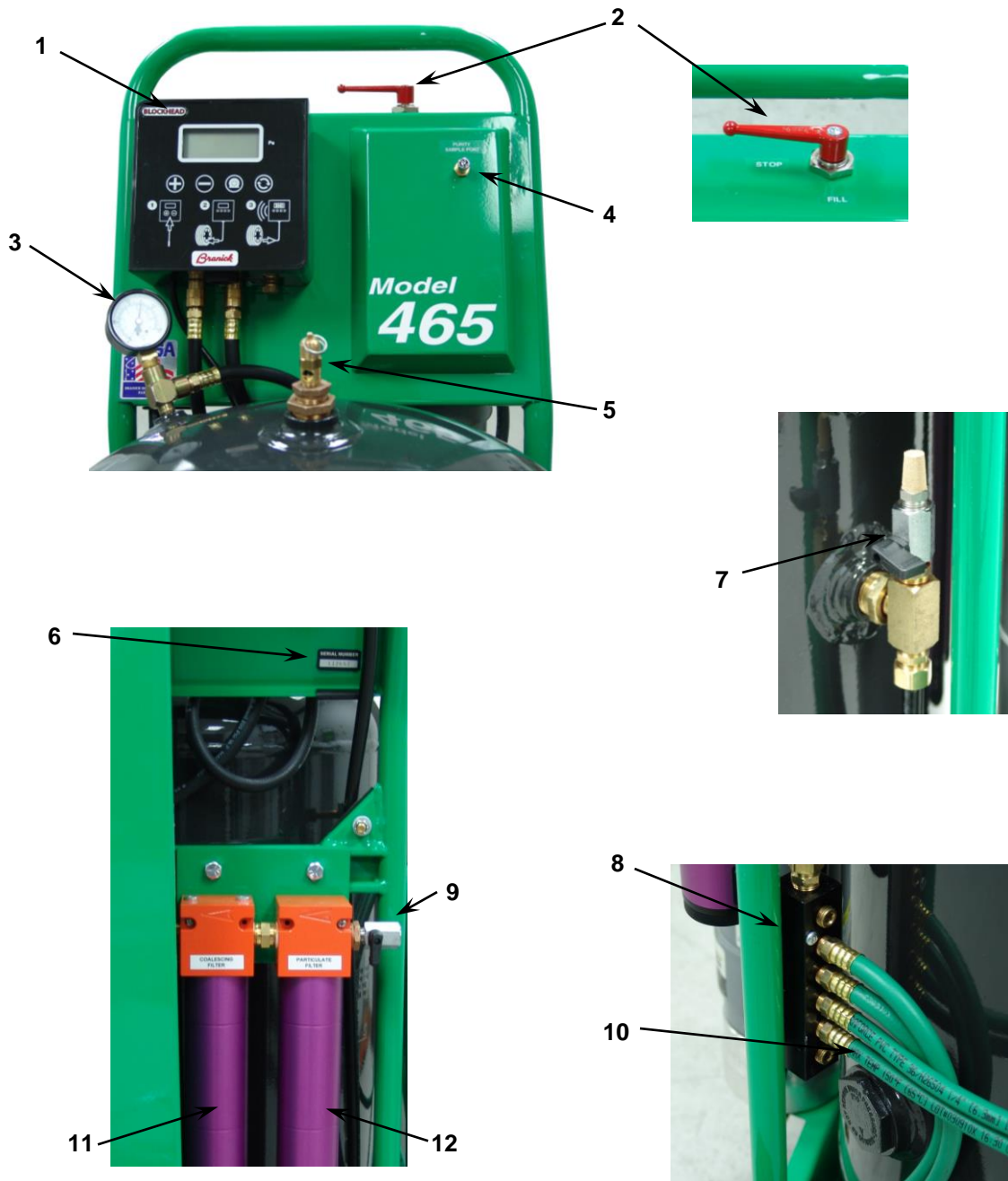

-
- | | | | |
|---|-------------------------------|----|-------------------------------------|
| 1 | Digital Inflator | 7 | Tank Purge Valve |
| 2 | Fill Control Valve (Inflator) | 8 | 6 Port Manifold |
| 3 | Nitrogen Tank Pressure Gauge | 9 | Air Inlet On/Off Valve (Air Supply) |
| 4 | Nitrogen Sampling Port | 10 | 25' Hose Assemblies |
| 5 | Pop Off Valve | 11 | Oil Coalescer Filter |
| 6 | Serial # Tag | 12 | Water Separator Filter |
-

OPERATING INSTRUCTIONS

Converting air filled tires to Nitrogen

1. Place the Fill Control Valve handle to the STOP position and plug in inflator to turn on the power.
2. Firmly attach the tire fill hoses to the valve stems of the tire and ensure that leaks do not exist.
3. Set the tire pressure with the ⊕ and ⊖ buttons on the inflator.

Note: The target pressure should be the vehicles recommended tire pressure found on the sticker inside the driver's door jamb or inside the fuel access door.

4. Turn the Fill Control Valve handle to FILL.
5. Press the ⊙ button to start the Nitrogen conversion.
6. When the alarm sounds the cycle is complete.
7. Turn the Fill Control Valve handle to STOP and remove hoses from valve stems.
8. To turn off the power to the inflator, unplug from receptacle.

Filling Tires to two different pressures

Some vehicles require two different tire pressure settings from the front tires to the rear. In this example, use target pressures of 32 psi in the front and 40 psi in the rear.

1. Go through steps 1 through 6, as mentioned above in "Converting Air-filled Tires to Nitrogen" using the lowest of the two pressures (32 psi) as the target pressure.
2. After getting through step 6, turn Fill Control Valve handle to STOP. Disconnect the hoses from the tires that are at their final pressure (In this example the front tires are at 32 psi).
3. Change the final pressure for the remaining two tires using ⊕ or ⊖ buttons (to 40 psi with the + button for this example).
4. Turn the red Fill Control Valve handle to 'FILL' position.
5. Press the ⊙ button.
6. When the alarm sounds the cycle is complete.
7. Turn the Fill Control Valve handle to STOP and remove hoses from valve stems.
8. To turn off the power to the inflator, unplug from receptacle.

DIGITAL INFLATOR OPERATING INSTRUCTIONS

See QUBE Inflator User Manual (P/N: 81-0213)

PART NUMBER	
SERIAL NUMBER	

QUBE Inflator User Manual

Please read and save these instructions. Read carefully before attempting to assemble, install, operate or maintain the product described. Protect yourself and others by observing all safety information. Failure to comply with instructions could result in personal injury and/or property damage! Retain instructions for future reference.

Safety Guidelines

This manual contains information that is very important to know and understand. This information is provided for safety and to prevent Equipment Problems. To help recognize this information, observe the following symbols.

	DANGER indicates an imminently hazardous situation which if not avoided WILL result in death or serious injury.
	WARNING indicates a potentially hazardous situation which if not avoided, COULD result in death or serious injury.
	CAUTION indicates a potentially minor or moderate injury.
	NOTICE indicates important information that if not followed, may cause damage to equipment.

Unpacking

After unpacking the unit, inspect carefully for any damage that may have occurred during transit.

	Do not operate unit if damaged. Damage may result in burning and cause injury or property damage.
--	---

Safety Information

The operator of this product must take the necessary precautions to prevent the level of danger indicated by these symbols. The operator is required to read and understand this instruction manual and all safety warnings, labels, etc.



Any employer allowing the use of this product in their field of work must distribute this instruction manual to all users. The employer must also ensure all users read, understand and follow the instructions as described in the manual, safety warnings, labels, etc.

	Read and understand all safety warnings and instructions before operating this product. Failure to read and follow all safety warnings may result in serious personal injury or death.
--	--

1. Do not expose the product to flammable gases, vapors or fumes.
2. Do not store flammable gases in or near this product.
3. Never use flammable or toxic solvents to clean the product or any of the unit's parts.
4. Never remove or alter any safety warning labels, tags, etc., located or provided with product.
5. Follow all directions for maintenance.

The unit is designed and built due to the relevant basic health and safety requirements of the EC guidelines.

REV020811 P/N: 81-0213A

MAINTENANCE

NOTE: To avoid personal injury or damage to the Nitrogen Inflation System, permit only qualified personnel to perform maintenance. **When cleaning or replacing filter elements and automatic float drains, turn the Air Inlet On/Off valve to “OFF”.**

See repair parts breakdown for replacement parts.

ALWAYS: Keep Nitrogen Inflation System clean.

DAILY: Check the automatic float drain on both filters for proper operation.

If the automatic float drain should become stuck open or inoperable, shut off the air supply (see NOTE above). Remove the bottom cap from the bottom of the filter. The drain can be cleaned in hot soapy water. DO NOT attempt to disassemble the drain. If the drain is still inoperable after cleaning, it will have to be replaced. When installing a new drain, make sure the o-ring is installed on the bottom stem before screwing it into the bottom cap. Finger tighten only.

The particulate filter element is stainless steel and should never need replacing.

The element can be removed and cleaned with soap & water and reinstalled.

Replace .01 micron coalescing filter element (right filter).

Order part number 05-0062 .01 Micron coalescing filter element (2-pack).

WEEKLY: Clean the automatic float drain on both filters.

See above.

BI-YEARLY: Clean particulate filter element and replace coalescing element.

OWNER'S RECORDS

Date Installed: _____

Serial number _____ *Located behind front panel*

HOSE CONNECTING LEGEND

EXAMPLE: A2 A = HOSE "A"
 2 = FIGURE NUMBER

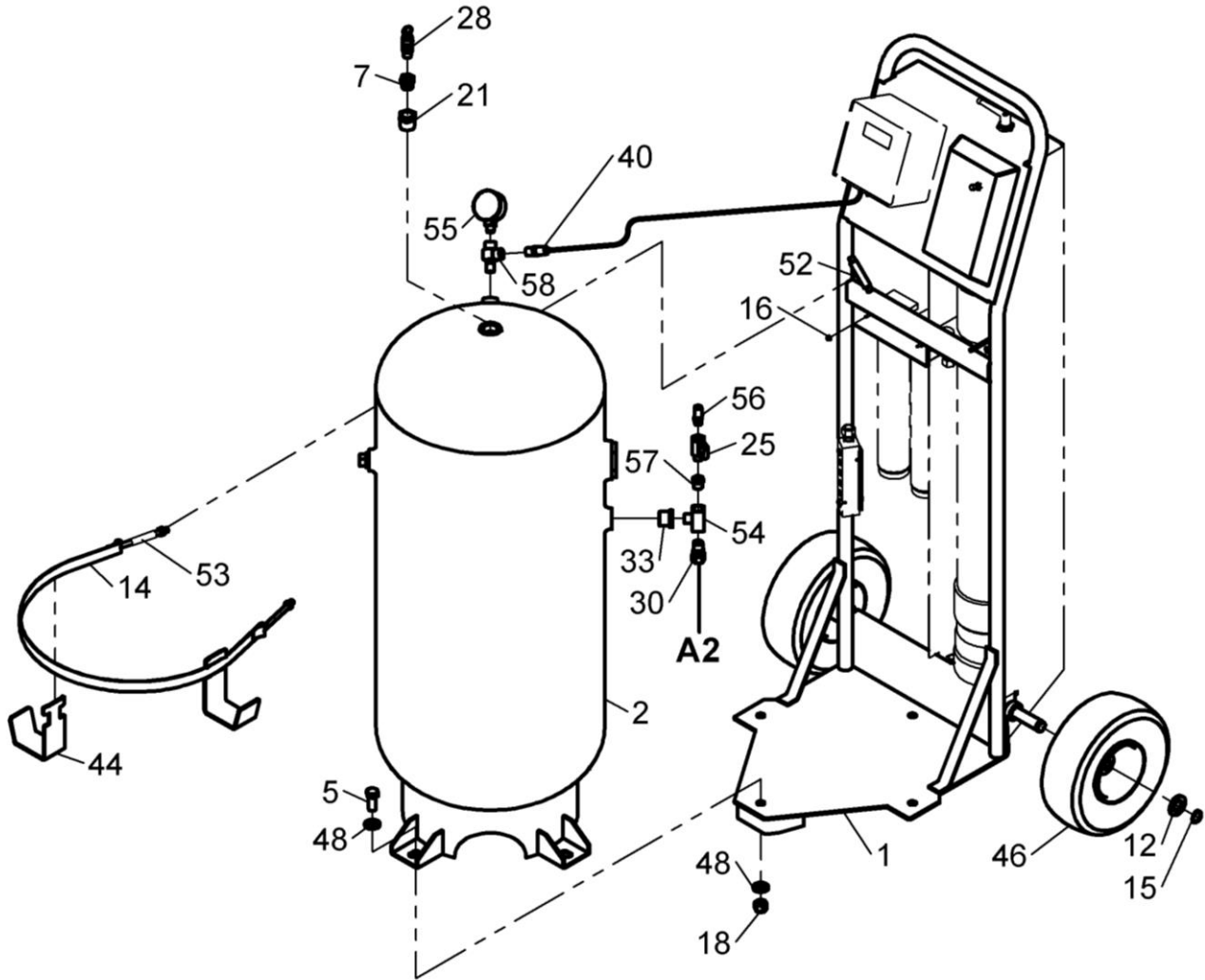

Frame & Tank Detail

FIGURE 1

REPAIR PARTS

HOSE CONNECTING LEGEND

EXAMPLE: A2 A = HOSE "A"
 2 = FIGURE NUMBER

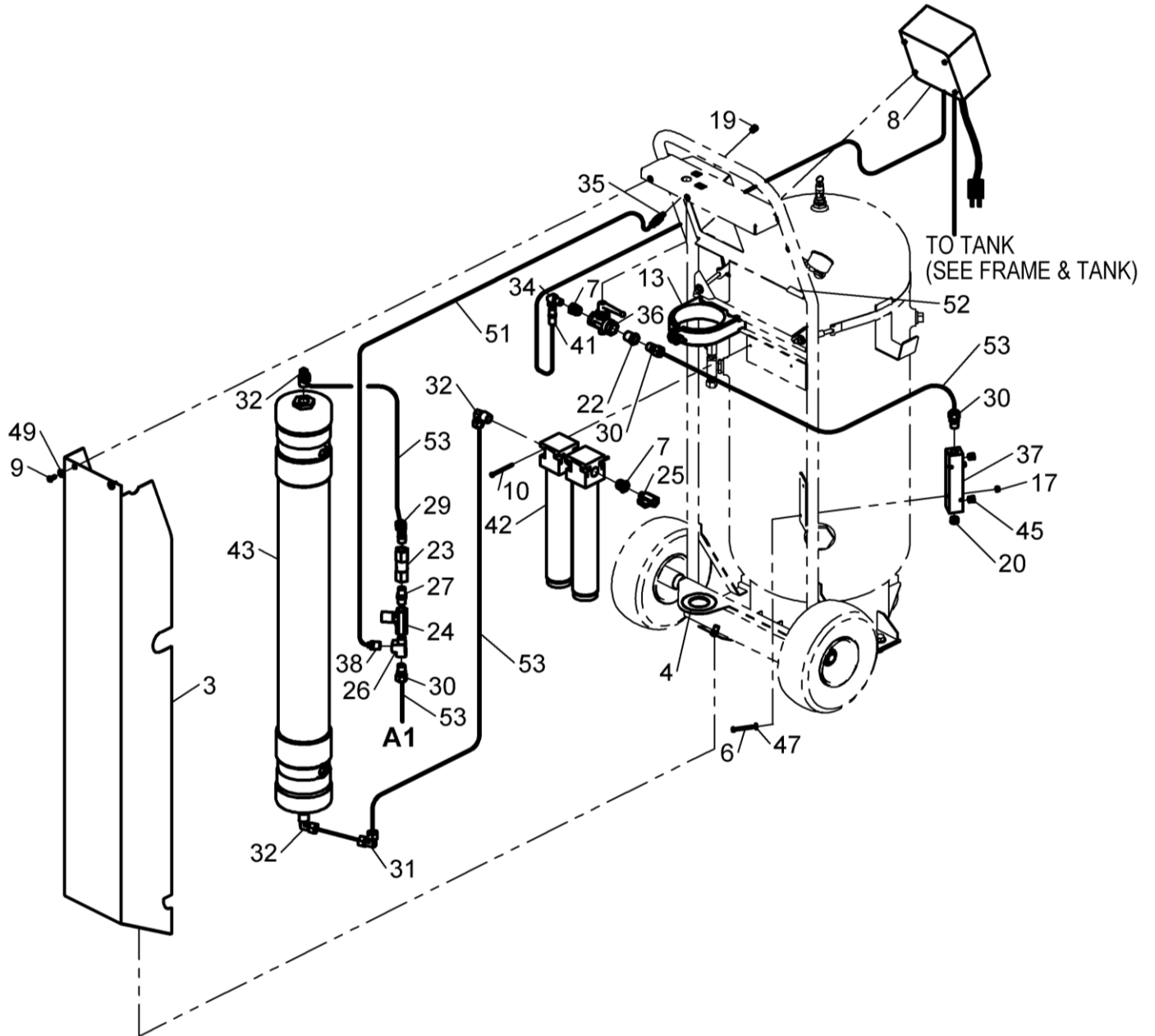

Pneumatic & Electrical Detail

FIGURE 2

REPAIR PARTS LIST

ITEM	QTY	PART NO.	DESCRIPTION	
1	1	03-0524	BASE & FRAME	
2	1	06-0016	30 GAL. TANK	
3	1	06-0118	BACK COVER	
4	1	10-0031	FOAM PAD	
5	4	028-034	1/2-13 X 1-1/4 HHC SCREW	
6	2	028-307	#10-24 UNC PHM SCREW	
7	3	039-008	1/2 TO 1/4 PIPE REDUCER	
8	1	40-0075	BLOCKHEAD	
9	3	50-0125	1/4-20 X 5/8 BTN HC SCREW	
10	2	50-0137	#8-32 X 2-1/2 PPHM SCREW	
11	3	51-0039	1/4-20 RIVET NUT	
12	2	52-0021	3/4 SAE FLAT WASHER	
13	1	53-0030	4-1/2 UNISTRUT CLAMP	
14	1	53-0032	TANK CLAMP	
15	2	54-0045	RETAINING RING	
16	2	055-082	#8-32 NYLOCK NUT	
17	2	055-127	#10-24 NYLOCK NUT	
18	4	055-156	1/2-13 NYLOCK NUT	
19	1	59-0021	CHROME BRASS VALVE STEM CAP	
20	1	60-0074	3/8 NPT PLUG	
21	1	60-0098	3/4 - 1/2 PIPE REDUCER	
22	1	60-0107	1/2 TO 3/8 PIPE REDUCER	
23	1	60-0114	CHECK VALVE	
24	1	60-0115	FLOW CONTROL VALVE	
25	2	60-0117	MINI BALL VALVE	
26	1	60-0132	3/8 NPT STREET TEE	
27	1	60-0134	3/8 NPT HEX NIPPLE	
28	1	60-0144	POP-OFF VALVE	
29	1	60-0175	1/2 TUBE TO 3/8 NPT M ELBOW	
30	4	60-0177	1/2 TUBE TO 3/8 NPT M CONNECTOR	
31	1	60-0180	1/2 TUBE UNION ELBOW	
32	3	60-0181	1/2 TUBE TO 1/2 NPT M ELBOW	
33	1	60-0190	3/4 TO 3/8 PIPE REDUCER	
34	1	60-0194	1/4 NPT M X F ELBOW	
35	1	60-0196	1/4 BULKHEAD VALVE	

ITEM	QTY	PART NO.	DESCRIPTION	ITEM
36	1	60-0208	BALL VALVE	
37	1	60-0229	6-PORT MANIFOLD	
38	1	60-0254	1/4 X 3/8 NPT M CONNECTOR	
39	4	62-0020	25' AIR HOSE ASS'Y	*
40	1	62-0034	17.50" HOSE ASS'Y	
41	1	62-0035	27.25" HOSE ASS'Y	
42	1	64-0016	FILTER ASS'Y	
43	1	64-0022	MEMBRANE	
44	2	72-0353	HOSE BRACKET	
45	2	096-004	1/4 NPT PLUG	
46	2	106-016	TIRE & WHEEL ASS'Y	
47	6	108-024	#10 SAE FLAT WASHER	
48	8	108-044	1/2 SAE FLAT WASHER	
49	3	108-110	1/4 SAE FLAT WASHER	
50	2	108-123	5/16 SAE FLAT WASHER	
51		D20-002	1/4 OD TUBE	
52		D20-014	RUBBER EDGING	
53		D20-031	1/2 OD TUBE	
54	1	60-0204	3/8 NPT M BRANCH TEE	
55	1	60-0323	2" 300 PSI GAUGE	
56	1	885-035	1/4 NPT MUFFLER	
57	1	096-039	3/8 TO 1/4 PIPE REDUCER	
58	1	096-155	1/4 NPT TEE	
59	1	64-0017	FILTER ELEMENT	*
60	1	64-0021	MESH FILTER ELEMENT	*
61	1	69-0020	AUTO FLOAT DRAIN	*

* Items not shown

Branick Industries, Inc.
Nitrogen Products
COMMERCIAL WARRANTY
(Non-Transferrable)

This product is warranted by BRANICK INDUSTRIES, INC. to the original user-owner against defective materials or workmanship. During the warranty period, if Branick determines the product or components to be defective, it will be repaired or replaced (at Branick's option).

	Warranty Period
Labor:	12 months from the date of delivery.
Parts:	12 months from the date of delivery.
Nitrogen Membranes:	60 month warranty from the date of delivery. Proper pre-filter maintenance must be followed as stated in this manual including changing filters every six (6) months, and using ONLY filters purchased through Branick. Not doing so will void the five year warranty. Contamination in the membrane including water, oil, solvents, particles, and other contaminants will void the warranty. Connecting to an airline with an oiler, or an unmaintained compressor will void the five year warranty. In order for a membrane to be considered for warranty replacement, it must be returned for inspection.
Service or Repair:	Warranty service or repairs must be performed by a Branick designated service company. Membranes replaced under warranty will remain under warranty for the remaining portion of the original warranty period.

This warranty does not cover damage to the product caused by abuse, misuse, overloading, accident (including shipping damage), improper maintenance, alteration, or any other cause not the result of defective materials or workmanship.

Replacement is the exclusive remedy for defective product under this warranty. This warranty is expressly in lieu of all other warranties, including any implied warranty of merchantability or any implied warranty of fitness for a particular purpose of this product. Branick industries, inc. Shall not be liable for any consequential or incidental damages.

BRANICK INDUSTRIES, INC. reserves the right to make changes in the design or construction of our products without obligation to incorporate such changes in products already sold and without notice.

Service parts, warranty, and regular repair service for **Nitrogen products** are available Monday through Friday, 7:30am to 4:30pm CST.

BRANICK INDUSTRIES, INC.
4245 Main Ave.
Fargo, North Dakota 58103
1-877-N2-HOTLINE
Email: sales@branick.com